

# *Grizzly* **Industrial, Inc.**®

## **MODEL G0702 12" DISC SANDER w/BRAKE OWNER'S MANUAL**



COPYRIGHT © SEPTEMBER, 2009 BY GRIZZLY INDUSTRIAL, INC.  
**WARNING: NO PORTION OF THIS MANUAL MAY BE REPRODUCED IN ANY SHAPE  
OR FORM WITHOUT THE WRITTEN APPROVAL OF GRIZZLY INDUSTRIAL, INC.**  
(FOR MODELS MANUFACTURED SINCE 8/09) #CR12124 PRINTED IN TAIWAN.

 **WARNING!**

**This manual provides critical safety instructions on the proper setup, operation, maintenance and service of this machine/equipment.**

**Failure to read, understand and follow the instructions given in this manual may result in serious personal injury, including amputation, electrocution or death.**

**The owner of this machine/equipment is solely responsible for its safe use. This responsibility includes but is not limited to proper installation in a safe environment, personnel training and usage authorization, proper inspection and maintenance, manual availability and comprehension, application of safety devices, blade/cutter integrity, and the usage of personal protective equipment.**

**The manufacturer will not be held liable for injury or property damage from negligence, improper training, machine modifications or misuse.**

 **WARNING!**

**Some dust created by power sanding, sawing, grinding, drilling, and other construction activities contains chemicals known to the State of California to cause cancer, birth defects or other reproductive harm. Some examples of these chemicals are:**

- **Lead from lead-based paints.**
- **Crystalline silica from bricks, cement and other masonry products.**
- **Arsenic and chromium from chemically-treated lumber.**

**Your risk from these exposures varies, depending on how often you do this type of work. To reduce your exposure to these chemicals: Work in a well ventilated area, and work with approved safety equipment, such as those dust masks that are specially designed to filter out microscopic particles.**

# Table of Contents

- INTRODUCTION..... 2**
  - Manual Accuracy..... 2
  - Contact Info..... 2
  - Machine Description..... 2
  - Machine Data Sheet..... 3
  - Identification ..... 4
- SECTION 1: SAFETY ..... 5**
  - Safety Instructions for Machinery..... 5
  - Additional Safety Instructions for Sanders ..... 7
- SECTION 2: CIRCUIT REQUIREMENTS ..... 8**
  - 110V Operation ..... 8
- SECTION 3: SETUP ..... 9**
  - Unpacking ..... 9
  - Inventory..... 9
  - Cleanup..... 10
  - Site Considerations ..... 11
  - Mounting..... 12
  - Test Run..... 13
- SECTION 4: OPERATIONS ..... 14**
  - Operation Overview..... 14
  - Attaching Sandpaper..... 15
  - X & Y Miter Slots..... 15
  - Miter Sanding ..... 16
  - Angle Sanding..... 16
- SECTION 5: ACCESSORIES ..... 17**
- SECTION 6: MAINTENANCE..... 18**
  - Schedule ..... 18
  - Cleaning ..... 18
  - Lubrication..... 18
  - Unpainted Cast Iron ..... 18
- SECTION 7: SERVICE ..... 19**
  - Troubleshooting..... 19
  - Table/Disc Parallelism..... 21
  - Miter Gauge Calibration ..... 21
  - Table Tilt Calibration ..... 22
- SECTION 8: WIRING..... 23**
  - Wiring Safety Instructions ..... 23
  - Wiring Diagram..... 24
- SECTION 9: PARTS..... 25**
  - Main Breakdown and Parts List ..... 25
  - Label Parts List ..... 26
- WARRANTY AND RETURNS ..... 29**



# INTRODUCTION

## Manual Accuracy

We are proud to offer this manual with your new machine! We've made every effort to be exact with the instructions, specifications, drawings, and photographs of the machine we used when writing this manual. However, sometimes errors do happen and we apologize for them.

Also, owing to our policy of continuous improvement, **your machine may not exactly match the manual**. If you find this to be the case, and the difference between the manual and machine leaves you in doubt, check our website for the latest manual update or call technical support for help.

Before calling, find the manufacture date of your machine by looking at the date stamped into the machine ID label (see below). This will help us determine if the manual version you received matches the manufacture date of your machine.

		<b>MODEL GXXXX</b> <b>MACHINE NAME</b>	
<b>SPECIFICATIONS</b>		<b>WARNING!</b>	
Motor:		<b>Manufacture Date of Your Machine</b> ing this machine: operation. s and respirator. sted/setup and suit before starting.	
Specification:			
Specification:			
Specification:			
Weight:			
<input type="text"/>	Date		
<input type="text"/>	Serial Number		
Manufactured for Grizzly in Taiwan			
4. make sure the motor has stopped and disconnect power before adjustments, maintenance, or service.			
5. DO NOT expose to rain or dampness.			
6. DO NOT modify this machine in any way.			
7. DO NOT remove safety guards.			
8. Never leave machine running unattended.			
9. DO NOT operate under the influence of drugs or alcohol.			
10. Maintain machine carefully to prevent accidents.			

For your convenience, we post all available manuals and manual updates for free on our website at [www.grizzly.com](http://www.grizzly.com). Any updates to your model of machine will be reflected in these documents as soon as they are complete.

## Contact Info

We stand behind our machines. If you have any service questions, parts requests or general questions about the machine, please call or write us at the location listed below.

Grizzly Industrial, Inc.  
1203 Lycoming Mall Circle  
Muncy, PA 17756  
Phone: (570) 546-9663  
Fax: (800) 438-5901  
E-Mail: [techsupport@grizzly.com](mailto:techsupport@grizzly.com)

If you have any comments regarding this manual, please write to us at the address below:

Grizzly Industrial, Inc.  
c/o Technical Documentation Manager  
P.O. Box 2069  
Bellingham, WA 98227-2069  
Email: [manuals@grizzly.com](mailto:manuals@grizzly.com)

## Machine Description

The Model G0702 Disc Sander features a 1 HP, 110V, 1725 RPM motor equipped with a motor brake and a 12" diameter sanding disc. The precision ground cast iron table is cut with two miter slots that allow for an included miter gauge to move a workpiece in either an X or Y direction against the sanding disc. An adjustable miter gauge provides a means for angle sanding. A built in 2 1/2" OD dust port allows for dust collection. A selection of adhesive sanding discs are available through the Grizzly catalog.





# MACHINE DATA SHEET

Customer Service #: (570) 546-9663 · To Order Call: (800) 523-4777 · Fax #: (800) 438-5901

## MODEL G0702 12" DISC SANDER WITH BRAKE

### Product Dimensions:

Weight..... 103 lbs.  
Length/Width/Height..... 26-1/2 x 17-1/8 x 16-3/8 in.  
Foot Print (Length/Width)..... 26-1/2 x 17-1/8 in.

### Shipping Dimensions:

Type..... Cardboard  
Content..... Machine  
Weight..... 113 lbs.  
Length/Width/Height..... 26 x 18 x 17 in.

### Electrical:

Power Requirement..... 110V, Single-Phase, 60 Hz  
Switch..... Keyed Safety Switch  
Switch Voltage..... 110V  
Cord Length..... 5 feet  
Cord Gauge..... 16 gauge  
Minimum Circuit Size..... 15A  
Plug Included..... Yes  
Recommended Plug/Outlet Type..... NEMA 5-15

### Motors:

#### Main

Type..... TEFC Capacitor Start w/Brake  
Horsepower..... 1 HP  
Voltage..... 110V  
Phase..... Single-Phase  
Amps..... 12A  
Speed..... 1725 RPM  
Cycle..... 60 Hz  
Power Transfer ..... Direct Drive  
Bearings..... Sealed and Permanently Lubricated

### Main Specifications:

#### Table Info

Table Width..... 15 in.  
Table Length..... 15-1/2 in.  
Table Tilt..... -15 to +45 Degrees  
Miter Gauge Slot Width..... 5/8 in.  
Miter Gauge Slot Height..... 3/16 in.  
Disc Table Length..... 12 in.

#### Disc Info

Sanding Disc Speed..... 1725 RPM



# Identification

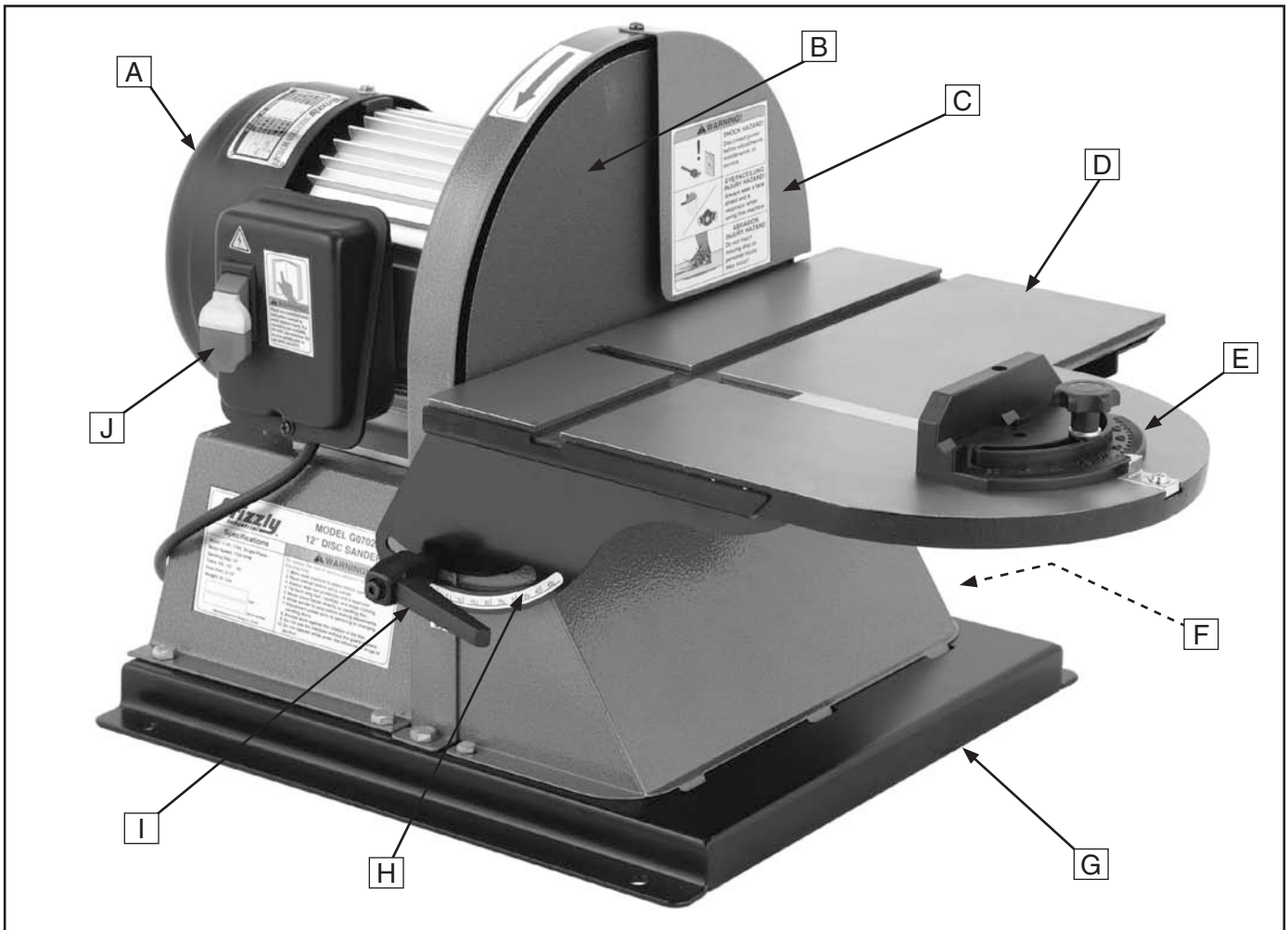

The following is a list of controls and components on the Model G0702 Disc Sander. Please take time to become familiar with each item and its location. These items will be used throughout the manual and knowing them is essential to understanding the instructions and terminology used in this manual.

- |  |   |
|--|---|
| <b>A.</b> Motor                                  | <b>F.</b> Dust Port (Opening Not Visible) |
| <b>B.</b> Cast Iron Disc (Sanding Disc Attached) | <b>G.</b> Adapter Base                    |
| <b>C.</b> Disc Guard                             | <b>H.</b> Tilt Scale                      |
| <b>D.</b> Extended Work Table                    | <b>I.</b> Universal Lock Lever            |
| <b>E.</b> Miter Gauge                            | <b>J.</b> Power Switch                    |



# SECTION 1: SAFETY

## WARNING

### For Your Own Safety, Read Instruction Manual Before Operating this Machine

The purpose of safety symbols is to attract your attention to possible hazardous conditions. This manual uses a series of symbols and signal words intended to convey the level of importance of the safety messages. The progression of symbols is described below. Remember that safety messages by themselves do not eliminate danger and are not a substitute for proper accident prevention measures.



Indicates an imminently hazardous situation which, if not avoided, **WILL** result in death or serious injury.



Indicates a potentially hazardous situation which, if not avoided, **COULD** result in death or serious injury.



Indicates a potentially hazardous situation which, if not avoided, **MAY** result in minor or moderate injury. It may also be used to alert against unsafe practices.

**NOTICE**

This symbol is used to alert the user to useful information about proper operation of the machine.

## WARNING

### Safety Instructions for Machinery

- 1. READ ENTIRE MANUAL BEFORE STARTING.** Operating machine before reading the manual greatly increases the risk of injury.
- 2. ALWAYS USE ANSI APPROVED SAFETY GLASSES WHEN OPERATING MACHINERY.** Everyday eyeglasses only have impact resistant lenses—they are NOT safety glasses.
- 3. ALWAYS WEAR A NIOSH APPROVED RESPIRATOR WHEN OPERATING MACHINERY THAT PRODUCES DUST.** Most types of dust (wood, metal, etc.) can cause severe respiratory illnesses.
- 4. ALWAYS USE HEARING PROTECTION WHEN OPERATING MACHINERY.** Machinery noise can cause permanent hearing loss.
- 5. WEAR PROPER APPAREL. DO NOT** wear loose clothing, gloves, neckties, rings, or jewelry that can catch in moving parts. Wear protective hair covering to contain long hair and wear non-slip footwear.
- 6. NEVER OPERATE MACHINERY WHEN TIRED OR UNDER THE INFLUENCE OF DRUGS OR ALCOHOL.** Be mentally alert at all times when running machinery.



# WARNING

## Safety Instructions for Machinery

7. **ONLY ALLOW TRAINED AND PROPERLY SUPERVISED PERSONNEL TO OPERATE MACHINERY.** Make sure operation instructions are safe and clearly understood.
8. **KEEP CHILDREN/VISITORS AWAY.** Keep all children and visitors away from machinery. When machine is not in use, disconnect it from power, lock it out, or disable the switch to make it difficult for unauthorized people to start the machine.
9. **UNATTENDED OPERATION.** Leaving machine unattended while its running greatly increases the risk of an accident or property damage. Turn machine **OFF** and allow all moving parts to come to a complete stop before walking away.
10. **DO NOT USE IN DANGEROUS ENVIRONMENTS.** DO NOT use machinery in damp, wet locations, or where any flammable or noxious fumes may exist.
11. **KEEP WORK AREA CLEAN AND WELL LIGHTED.** Clutter and dark shadows may cause accidents.
12. **USE A GROUNDED POWER SUPPLY RATED FOR THE MACHINE AMPERAGE.** Grounded cords minimize shock hazards. Operating machine on an incorrect size of circuit increases risk of fire.
13. **ALWAYS DISCONNECT FROM POWER SOURCE BEFORE SERVICING MACHINERY.** Make sure switch is in OFF position before reconnecting.
14. **MAINTAIN MACHINERY WITH CARE.** Keep blades sharp and clean for best and safest performance. Follow instructions for lubricating and changing accessories.
15. **MAKE SURE GUARDS ARE IN PLACE AND WORK CORRECTLY BEFORE USING MACHINERY.**
16. **REMOVE CHUCK KEYS OR ADJUSTING TOOLS.** Make a habit of never leaving chuck keys or other adjustment tools in/on the machine—especially near spindles!
17. **DAMAGED MACHINERY.** Check for binding or misaligned parts, broken parts, loose bolts, other conditions that may impair machine operation. Always repair or replace damaged parts before operation.
18. **DO NOT FORCE MACHINERY.** Work at the speed for which the machine or accessory was designed.
19. **SECURE WORKPIECE.** Use clamps or a vise to hold the workpiece when practical. A secured workpiece protects your hands and frees both hands to operate the machine.
20. **DO NOT OVERREACH.** Maintain stability and balance at all times when operating machine.
21. **MANY MACHINES CAN EJECT WORKPIECES TOWARD OPERATOR.** Know and avoid conditions that cause the workpiece to "kickback."
22. **STABLE MACHINE.** Machines that move during operations greatly increase the risk of injury and loss of control. Verify machines are stable/secure and mobile bases (if used) are locked before starting.
23. **CERTAIN DUST MAY BE HAZARDOUS** to the respiratory systems of people and animals, especially fine dust. Be aware of the type of dust you are exposed to and always wear a respirator designed to filter that type of dust.
24. **EXPERIENCING DIFFICULTIES.** If at any time you are experiencing difficulties performing the intended operation, stop using the machine! Contact our Technical Support Department at (570) 546-9663.





## **WARNING**

# Additional Safety Instructions for Sanders

1. **AVOIDING WORKPIECE GRAB.** Never attempt to sand with a damaged or badly worn sanding disc or if sanding disc adhesion is questionable. If sandpaper rips or comes off of the disc during operation, severe injury could occur.
2. **AVOIDING KICKBACK.** Never use excessive force, or push the workpiece upward and into the sanding disc against the direction of rotation. Otherwise the potential of workpiece kickback is increased.
3. **SAFE SERVICING.** Disconnect the machine from power and allow the disc to come to a complete stop before service, maintenance, or adjustments.
4. **SAFE SANDING OPERATIONS.** If there is any doubt about stability or integrity of the material to be sanded, **do not sand it.**
5. **AVOIDING ENTANGLEMENT.** Never attempt to sand any sort of cable, chain, or wire. If you do entanglement can occur causing serious injury.
6. **PREVENTING FINGER INJURIES.** Keep fingers away from sanding disc, and use a workpiece holding fixture when sanding small parts. Serious injury could result if skin contacts abrasives or moving parts.
7. **AVOIDING ENTANGLEMENT.** Tie back long hair and remove any loose-fitting clothing or jewelry that could be caught up in the sander's disc, belt, or other moving machine parts.
8. **DUST HAZARD.** Be aware that certain woods may cause an allergic reaction in people and animals, especially when exposed to fine dust. Make sure you know what type of wood dust you will be exposed to in case there is a possibility of an allergic reaction.
9. **WEAR RESPIRATOR.** This machine may blow fine dust particles into the air during operation causing a hazard to the lungs. Always wear an approved respirator during machine operation and for a short time after.

## **WARNING**

Like all machinery there is potential danger when operating this machine. Accidents are frequently caused by lack of familiarity or failure to pay attention. Use this machine with respect and caution to decrease the risk of operator injury. If normal safety precautions are overlooked or ignored, serious personal injury may occur.

## **CAUTION**

No list of safety guidelines can be complete. Every shop environment is different. Always consider safety first, as it applies to your individual working conditions. Use this and other machinery with caution and respect. Failure to do so could result in serious personal injury, damage to equipment, or poor work results.



# SECTION 2: CIRCUIT REQUIREMENTS

## 110V Operation

### **⚠ WARNING**

Serious personal injury could occur if you connect the machine to power before completing the setup process. **DO NOT** connect the machine to the power until instructed later in this manual.

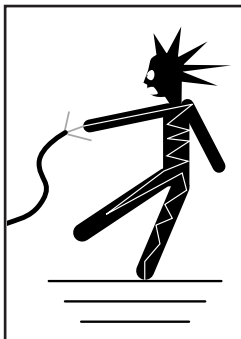

### **⚠ WARNING**

Electrocution or fire could result if machine is not correctly grounded or connected to the power source. Get help if you do not know what you are doing.

### Full Load Amperage Draw

This machine draws the following amps under maximum load:

Amp Draw..... 12 Amps

### Power Supply Circuit Requirements

The power supply circuit for your machine **MUST** be grounded and rated for the amperage given below. Never replace a circuit breaker on an existing circuit with one of higher amperage without consulting a qualified electrician to ensure compliance with wiring codes. **If you are unsure about the wiring codes in your area or you plan to connect your machine to a shared circuit, consult a qualified electrician.**

Minimum Circuit Size..... 15 Amps

### Power Connection Device

This machine comes with a plug, similar to **Figure 1**, to connect the machine to power.

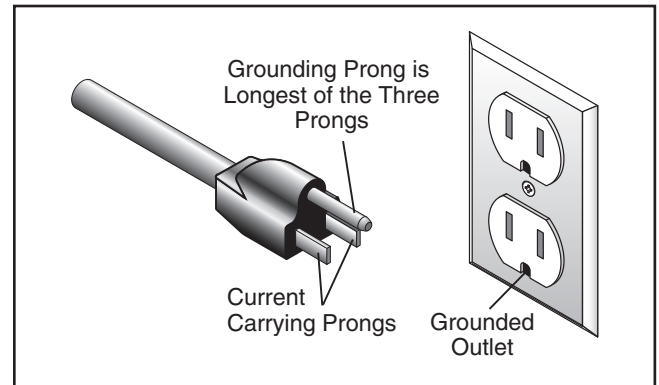

**Figure 1.** Typical 5-15 plug and receptacle.

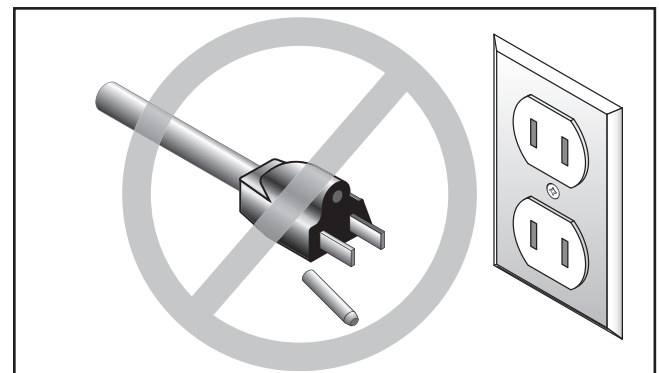

### **⚠ CAUTION**

This machine **MUST** have a ground prong in the plug to help ensure that it is grounded. **DO NOT** remove ground prong from plug to fit into a two-pronged outlet! If the plug will not fit the outlet, have the proper outlet installed by a qualified electrician.

### Extension Cords

We do not recommend using extension cords, but if you find it absolutely necessary:

- Use at least a 14 gauge cord that does not exceed 50 feet in length!
- The extension cord must have a ground wire and plug pin.
- A qualified electrician **MUST** size cords over 50 feet long to prevent motor damage.



# SECTION 3: SETUP

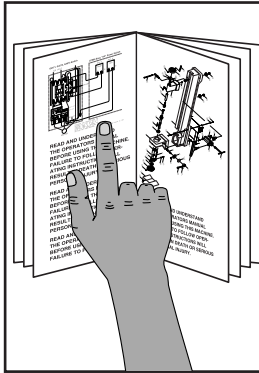

## **!WARNING**

This machine presents serious injury hazards to untrained users. Read through this entire manual to become familiar with the controls and operations before starting the machine!

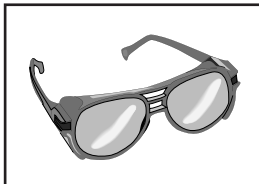

## **!WARNING**

Wear safety glasses during the entire setup process!

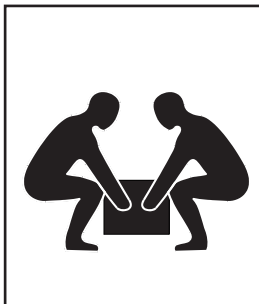

## **!WARNING**

This machine and its components are very heavy. Get lifting help or use power lifting equipment such as a forklift to move heavy items.

## Unpacking

Your machine was carefully packaged for safe transportation. Remove the packaging materials from around your machine and inspect it. If you discover the machine is damaged, *please immediately call Customer Service at (570) 546-9663 for advice.*

Save the containers and all packing materials for possible inspection by the carrier or its agent. *Otherwise, filing a freight claim can be difficult.*

When you are completely satisfied with the condition of your shipment, inventory the contents.

## Inventory

The following is a description of the main components shipped with your machine. Lay the components out to inventory them.

**Note:** *If you can't find an item on this list, check the mounting location on the machine or examine the packaging materials carefully. Occasionally we pre-install certain components for shipping purposes.*

Description	Qty
• Sander Assembly .....	1
• Sanding Disc (Installed) .....	1
• Miter Gauge.....	1
• Handle .....	1
• Cap Screw M6-1 x 20 .....	2

If any non proprietary parts are missing (e.g. a nut or a washer), we will gladly replace them; or for the sake of expediency, replacements can be obtained at your local hardware store.



# Cleanup

The unpainted surfaces of your machine are coated with a heavy-duty rust preventative that prevents corrosion during shipment and storage.

This rust preventative has been your machine's close ally and guardian since it left the factory. If your machine arrived to you free of rust, then be thankful that the rust preventative protected it during its journey...and try to stay thankful as you clean it off, because it can be challenging to remove if you are unprepared and impatient.

Plan on spending some time cleaning your machine. The time you spend doing this will reward you with smooth sliding parts and a better appreciation for the proper care of your machine's unpainted surfaces.

Although there are many ways to successfully remove the rust preventative, these instructions walk you through what works well for us.

## Before cleaning, gather the following:

- Disposable Rags
- Cleaner/degreaser (see below)
- Safety glasses & disposable gloves

## H9692—Orange Power Cleaner & Degreaser

One of the best cleaners we've found for quickly and easily removing rust preventative.



**Figure 2.** Model H9692 Industrial Orange Power Cleaner/Degreaser (99.9% biodegradable).

**Note:** In a pinch, automotive degreasers, mineral spirits or WD•40 can be used to remove rust preventative. Before using these products, though, test them on an unnoticeable area of your paint to make sure they will not damage it.

	<b>WARNING</b> Gasoline and petroleum products have low flash points and can explode or cause fire if used to clean machinery. Avoid using these products to clean machinery.
--	--

	<b>CAUTION</b> Many cleaning solvents are toxic if inhaled. Minimize your risk by only using these products in a well ventilated area.
--	---

<b>NOTICE</b> Avoid chlorine-based solvents, such as acetone or brake parts cleaner that may damage painted surfaces. Always follow the manufacturer's instructions when using any type of cleaning product.
---

## Basic steps for removing rust preventative:

1. Put on safety glasses and disposable gloves.
2. Coat all surfaces that have rust preventative with a liberal amount of your cleaner/degreaser and let them soak for few minutes.
3. Wipe off the surfaces. If your cleaner/degreaser is effective, the rust preventative will wipe off easily.

**Note:** To clean off thick coats of rust preventative on flat surfaces, such as tables, use a **PLASTIC** paint scraper to scrape off the majority of the coating before wiping it off with your rag. (Do not use a metal scraper or you may scratch your machine.)

4. Repeat **Steps 2–3** as necessary until clean, then coat all unpainted surfaces with a quality metal protectant to prevent rust.



# Site Considerations

## Weight Load

Refer to the **Machine Data Sheet** for the weight of your machine. Make sure that the surface upon which the machine is placed will bear the weight of the machine, additional equipment that may be installed on the machine, and the heaviest workpiece that will be used. Additionally, consider the weight of the operator and any dynamic loading that may occur when operating the machine.

## Space Allocation

Consider the largest size of workpiece that will be processed through this machine and provide enough space around the machine for adequate operator material handling or the installation of auxiliary equipment. With permanent installations, leave enough space around the machine to open or remove doors/covers as required by the maintenance and service described in this manual. **See below for working clearances.**

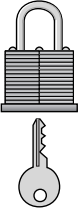
	<p><b>CAUTION</b> Children or untrained people may be seriously injured by this machine. Only install in an access restricted location.</p>
---	---

## Physical Environment

The physical environment where your machine is operated is important for safe operation and the longevity of its components. For best results, operate this machine in a dry environment that is free from excessive moisture, hazardous chemicals, airborne abrasives, or extreme conditions. Extreme conditions for this type of machinery are generally those where the ambient temperature range exceeds 41°–104°F; the relative humidity range exceeds 20–95% (non-condensing); or the environment is subject to vibration, shocks, or bumps.

## Electrical Installation

Place this machine near an existing power source. Make sure all power cords are protected from traffic, material handling, moisture, chemicals, or other hazards. Make sure to leave access to a means of disconnecting the power source or engaging a lockout/tagout device.

## Lighting

Lighting around the machine must be adequate enough that operations can be performed safely. Shadows, glare, or strobe effects that may distract or impede the operator must be eliminated.

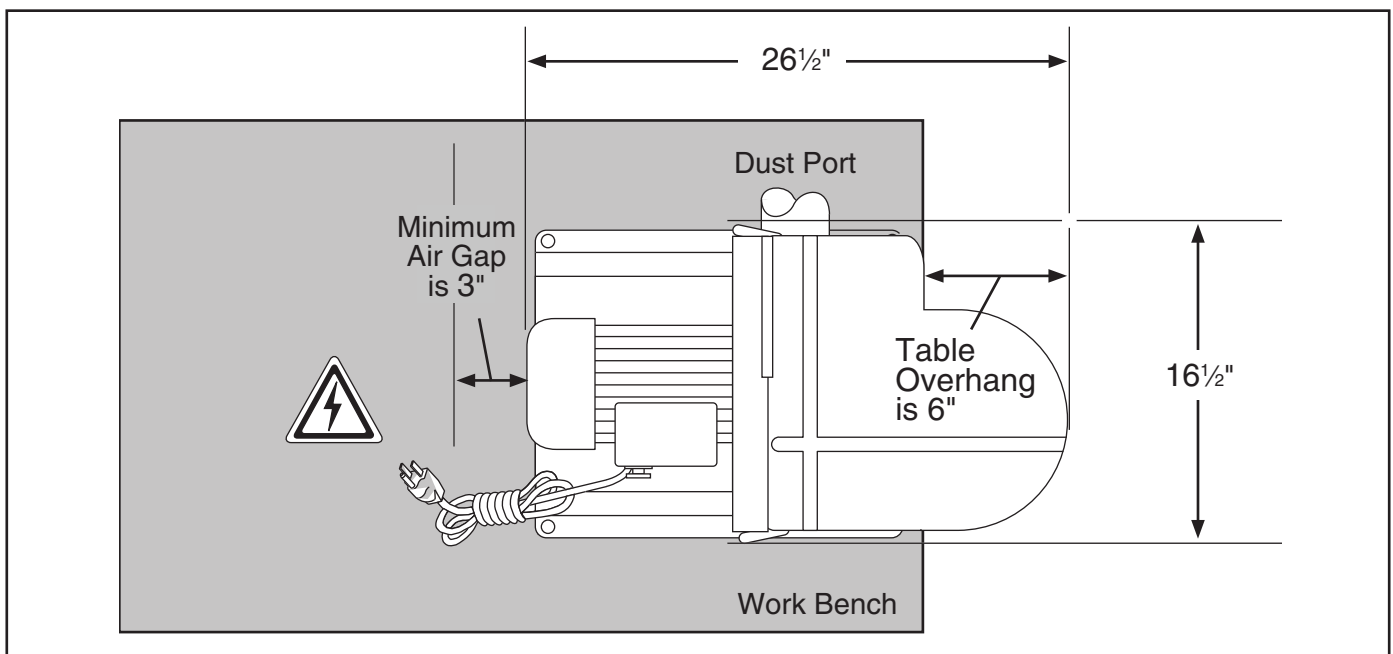

**Figure 3.** Minimum working clearances.



# Mounting

We strongly recommend that you mount your sander to a workbench to prevent it from moving during operation. An unexpected movement could result in an injury or property damage.

There are two machine positioning scenarios that also must be recognized. If the sander is mounted directly to a workbench surface, the extended sanding table will contact the workbench top and stop at 35° instead of 45°. To prevent this contact, the sander must be mounted so 6" of the cast iron table overhangs past the workbench edge (**Figure 3**), or the sander can be mounted upon a 2½" thick riser block, which is fastened to the table. In either of these positions the table will then be able to reach a full tilt of 45°.

When you have chosen the location to mount the sander, the strongest mounting option is the "Through Mount" option (**Figure 4**) where the holes are drilled all the way through the workbench and hex bolts, washers, and hex nuts are used to secure the machine.

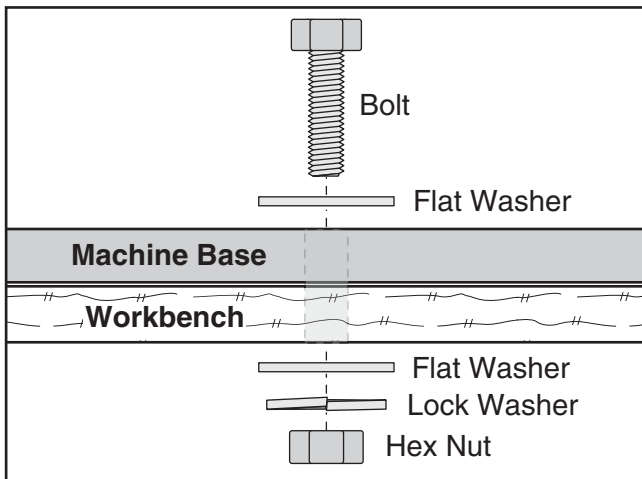

**Figure 4.** Example of a through mount setup.

Another option for mounting is a "Direct Mount" (**Figure 5**) where the machine is simply secured to the workbench with a lag screw.

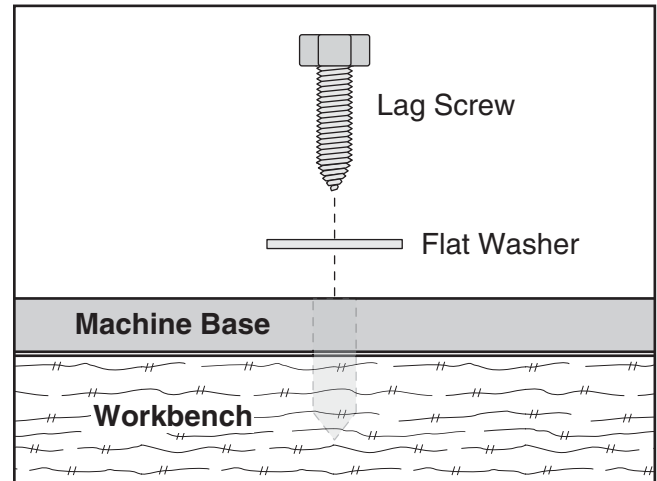

**Figure 5.** Example of a direct mount setup.



# Test Run

---

Once the assembly is complete, test run your machine to make sure it runs properly and is ready for regular operation.

The test run consists of verifying the following:

- 1) The motor powers up and runs correctly, and
- 2) the safety disabling mechanism on the switch works correctly.

If, during the test run, you cannot easily locate the source of an unusual noise or vibration, stop using the machine immediately, then review **Troubleshooting** on **Page 19**.

If you still cannot remedy a problem, contact our Tech Support at (570) 546-9663 for assistance.

## To test run the machine:

1. Rotate the disc by hand and make sure it turns freely.
2. Make sure you have read the safety instructions at the beginning of the manual and that the machine is setup properly.
3. Make sure all tools and objects used during setup are cleared away from the machine.
4. Connect the machine to the power source.
5. Verify that the machine is operating correctly by turning the machine **ON**.

—When operating correctly, the machine runs smoothly with little or no vibration or rubbing noises.

—Investigate and correct strange or unusual noises or vibrations before operating the machine further. Always disconnect the machine from power when investigating or correcting potential problems.

6. Turn the machine **OFF**.
7. Remove the switch disabling key, as shown in **Figure 6**.

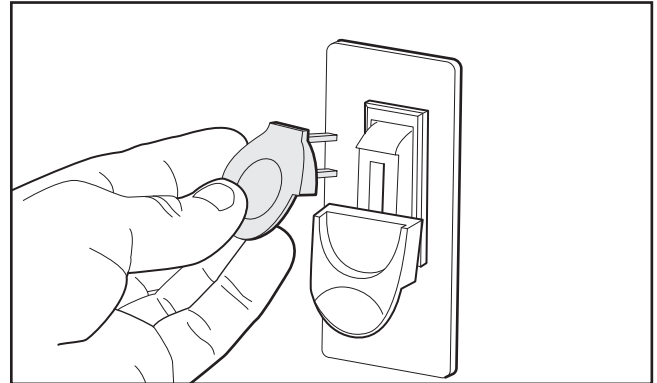
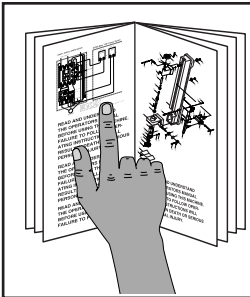

**Figure 6.** Removing switch key from paddle switch.

8. Try to turn the start the machine with the paddle switch.
  - If the machine does not start, the switch disabling feature is working as designed.
  - If the machine starts, immediately stop the machine. The switch disabling feature is not working correctly. This safety feature must work properly before proceeding with regular operations. Call Tech Support for help.



# SECTION 4: OPERATIONS



## **!WARNING**

To reduce the risk of serious injury when using this machine, read and understand this entire manual before beginning any operations.

## **!WARNING**

Damage to your eyes and lungs could result from using this machine without proper protective gear. Always wear safety glasses and a respirator when operating this machine.

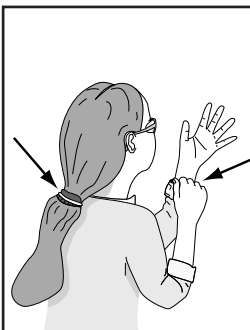
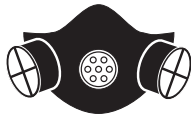

## **!WARNING**

Loose hair, clothing, or jewelry could get caught in machinery and cause serious personal injury. Keep these items away from moving parts at all times to reduce this risk.

## **NOTICE**

If you have never used this type of machine or equipment before, WE STRONGLY RECOMMEND that you read books, review industry trade magazines, or get formal training before beginning any projects. Regardless of the content in this section, Grizzly Industrial will not be held liable for accidents caused by lack of training.

## Operation Overview

This overview gives you the basic process that happens during an operation with this machine. Familiarize yourself with this process to better understand the **Operations** section.

To complete a sanding operation, the operator does the following:

1. Examines the workpiece to make sure it is suitable for sanding.
2. Adjusts the table tilt, if necessary, to the required sanding angle, and locks the table in place.
3. Inserts the miter bar in either the X-axis or Y-axis miter slots.
4. Adjusts the miter angle for the required horizontal sanding angle, and locks it in place.
5. Uses the appropriate clamping device or jig for small workpieces.
6. Wears safety glasses and a respirator, and locates push sticks if needed.
7. Starts the machine and dust collector.
8. Holds the workpiece firmly and flatly against both the table and miter, then pushes the workpiece into or along the sanding disc.
9. Moves the workpiece to different locations on the sanding disc to wear the sandpaper evenly and to prevent the sandpaper from overheating.
10. Stops the machine.





# Attaching Sandpaper

The Model G0702 sander accepts 12" diameter adhesive-backed sanding discs. These are available in a variety of grits. See the current Grizzly catalog for prices and ordering information.

The sanding disc sticks to the surface of the cast iron disc platen, using the pressure sensitive adhesive backing (PSA). The sandpaper can be replaced without removing either the table or the dust port.

## To attach sandpaper:

1. DISCONNECT MACHINE FROM POWER!
2. Remove the safety guard, peel-off the old sandpaper, and clean the disc surface with mineral spirits, and wipe dry.
3. Peel-back the protective layer on **one-half** of the sandpaper disc and fold it against the remaining half.
4. Slip the half with the protective layer between the disc and the table edge (**Figure 7**).



**Figure 7.** Sandpaper being slipped between the disc and table.

5. Position the exposed adhesive on the upper half of the disc that extends above the table. Once it is positioned evenly across the disc, press the adhesive onto the surface.

6. Now rotate the disc so the lower half is above the table and peel-off the other half of the protective paper, and press the sanding disc against the disc so adhesion is complete.
7. Reinstall the safety guard.

# X & Y Miter Slots

The Model G0702 uses dual-axis miter slot design for increased versatility of workpiece control or special jig or fixture mounting ability.

## To sand using the miter slot:

1. Set the angle of the table relative to the sanding disc. The angle can be set with the angle gauge on the disc sander or with a protractor for greater accuracy.
2. When a 90° horizontal angle is required, place one surface of the workpiece firmly against the face of the miter gauge (set at 90°) with the other surface against the face of the disc (**Figure 8**).



**Figure 8.** Miter slot and work path.

**Note:** For sanding curves or irregular shapes, remove the miter gauge from the disc table. Always keep the workpiece on the side of the wheel that is rotating down toward the table. This will keep the workpiece from flying out of your hands from the rotational forces.



# Miter Sanding

The most efficient way to get a perfect miter is to cut the workpiece slightly long and sand it to the desired dimension. Miter sanding can be done easily with the miter gauge.

## To perform miter sanding operations:

1. Loosen the knob on the miter gauge and adjust the angle to the desired point. Tighten the knob.

2. Slide the miter gauge into its slot and use it to hold your workpiece in position.

**Note:** The miter gauge can be used in either direction in the slot to achieve the proper relation of the workpiece to the disc.

3. With light, but firm pressure, push the workpiece slowly into the down-spin side of the rotating disc (**Figure 9**).



**Figure 9.** Angle sanding.

# Angle Sanding

The disc table can be positioned from  $-15^{\circ}$  to  $45^{\circ}$ , relative to the plane of the sanding disc. Sanding in an "open angle zone" rather than in a "closed angle zone" is typically safest (**Figure 10**). Understanding this relationship helps prevent trapping the workpiece between the sanding surface and the table, and reduces the hazard of workpiece kickback.

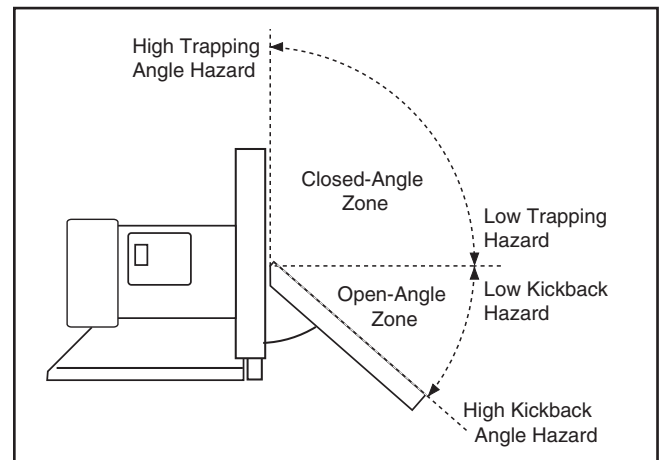

**Figure 10.** Trapping and kickback zones.

## To perform angle sanding operations:

1. Position the table to the desired angle as shown on the angle scale.
2. Use the miter gauge to hold your workpiece in position, and with light, but firm pressure, push the workpiece slowly into the down-spin side of the rotating disc (**Figure 11**).

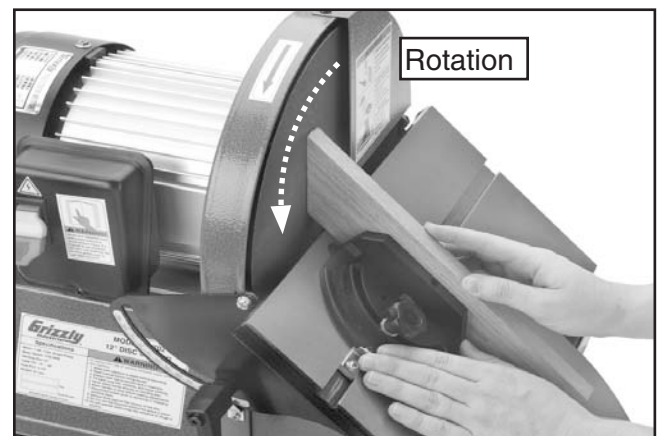

**Figure 11.** Sanding with table angled.



# SECTION 5: ACCESSORIES

## Sanding Discs from ISO 9002 Factories

MODEL and TYPE	GRIT
G1220 12" PSA.....	60
G4255 12" PSA.....	80
G1221 12" PSA.....	100
G4256 12" PSA.....	120
G1222 12" PSA.....	150
G4257 12" PSA.....	180
G4258 12" PSA.....	220



Figure 12. Sanding discs.

### G0572—Bench Top Dual Fan Dust Filter

This Hanging Air Filter has a convenient remote control and features a three speed motor, automatic shutoff timer and 1 micron inner filter and 5 micron outer filter. Air flow is 556, 702 and 1044 CFM. Overall size is 26"L x 19-1/2"W x 15"H.



Figure 13. G0572 Air filter.

## PRO-STICK® Abrasive Surface Cleaners

Extend the life of your sanding discs and sleeves! Choose the Pro-Stick® with a handle for greater control or without a handle for more usable area.

Size	Model
1½" X 1½" X 8½" .....	G1511
2" X 2" X 12".....	G1512
1½" X 1½" X 9" with Handle.....	G2519
2" X 2" X 11" with Handle.....	G2520



Figure 14. PRO-STICK® abrasive cleaners.

### G3119— 2½" x 3" Duct Adapter

### G3119— 2½" x 4" Duct Adapter

These direct sized dust collection adapters allow for slip on connection for Shop-vac® and Sears® port openings. These are also handy for the model G0702 disc sander dust port connection.

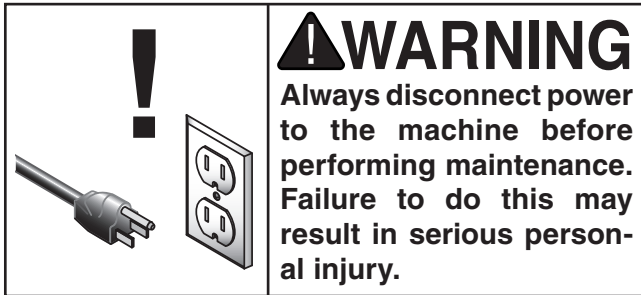

Figure 15. Sized dust collection adapters.

Call 1-800-523-4777 To Order



# SECTION 6: MAINTENANCE



## Schedule

For optimum performance from your machine, follow this maintenance schedule and refer to any specific instructions given in this section.

### Daily Check:

- Loose mounting bolts.
- Worn loose, or damaged sanding disc.
- Worn or damaged power cord.
- Any other condition that could hamper the safe operation of this machine.

### Weekly Maintenance:

- Wipe off the sawdust build-up from the table surface.
- Vacuum out dust from the motor fan area and from around the base of the machine.

### Long-Term Storage:

- Keep unpainted surfaces rust free with products such as Boeshield® T-9.

## Cleaning

Cleaning the Model GG0702 is easy. Vacuum excess wood chips and sawdust, and wipe off the remaining dust with a dry cloth. If any resin has built up, use a resin dissolving cleaner to remove it. Treat all unpainted cast iron and steel with a non-staining lubricant after cleaning.

## Lubrication

This machine uses permanently lubricated ball bearings. No bearing maintenance is required.

## Unpainted Cast Iron

Protect the unpainted cast iron surfaces on the table by wiping the table clean after every use—this ensures moisture from wood dust does not remain on bare metal surfaces.

Keep tables rust-free with regular applications of products like G96® Gun Treatment, SLIPIT®, or Boeshield® T-9 (**Figure 16**).

G5562—SLIPIT® 1 Qt. Gel

G5563—SLIPIT® 12 oz Spray

G2871—Boeshield® T-9 12 oz Spray

G2870—Boeshield® T-9 4 oz Spray

H3788—G96® Gun Treatment 12 oz Spray

H3789—G96® Gun Treatment 4.5 oz Spray



**Figure 16.** Recommended products for protecting unpainted cast iron/steel part on machinery.



# SECTION 7: SERVICE

Review the troubleshooting and procedures in this section to fix or adjust your machine if a problem develops. If you need replacement parts or you are unsure of your repair skills, then feel free to call our Technical Support at (570) 546-9663.

## Troubleshooting

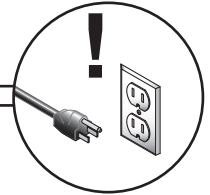

### Motor & Electrical

Symptom	Possible Cause	Possible Solution
Machine does not start.	<ol style="list-style-type: none"> <li>1. Switch disabling key removed.</li> <li>2. Break or short in wiring, loose connections, plug or receptacle is corroded or miswired.</li> <li>3. Power supply switched off/has incorrect voltage.</li> <li>4. Blown fuse/tripped circuit breaker at main panel.</li> <li>5. Motor connection wired incorrectly.</li> <li>6. Motor ON/OFF switch at fault.</li> <li>7. Start capacitor has blown.</li> <li>8. Centrifugal switch at fault.</li> <li>9. Motor at fault.</li> </ol>	<ol style="list-style-type: none"> <li>1. Reinstall switch disabling key.</li> <li>2. Trace/replace broken or corroded wires, fix loose connections, correct wiring.</li> <li>3. Switch power supply on/verify voltage.</li> <li>4. Correct the cause of overload, then reset/replace fuse or breaker.</li> <li>5. Wire motor correctly (refer to inside junction box cover or manual).</li> <li>6. Replace switch.</li> <li>7. Test/replace if at fault.</li> <li>8. Adjust/replace centrifugal switch.</li> <li>9. Test for shorted windings or bad bearings; repair or replace.</li> </ol>
Machine has excessive vibration or noise.	<ol style="list-style-type: none"> <li>1. Workpiece loose or incorrectly secured.</li> <li>2. Motor fan rubbing on fan cover.</li> <li>3. Motor mounting loose.</li> <li>4. Lock lever is loose.</li> <li>5. Machine incorrectly mounted to bench.</li> <li>6. Centrifugal switch out of adjustment; at fault.</li> <li>7. Motor bearings worn or damaged.</li> </ol>	<ol style="list-style-type: none"> <li>1. Use correct holding fixture and re-clamp workpiece.</li> <li>2. Fix/replace fan cover; replace loose or damaged fan.</li> <li>3. Tighten mounting bolts/nuts; use thread locking fluid.</li> <li>4. Tighten the lock lever.</li> <li>5. Level/shim base; tighten/adjust mounting hardware or feet.</li> <li>6. Adjust/replace centrifugal switch.</li> <li>7. Replace motor bearings or replace motor.</li> </ol>
Machine stalls or slows when operating.	<ol style="list-style-type: none"> <li>1. Too much pressure when feeding workpiece</li> <li>2. Workpiece is warped.</li> <li>3. Workpiece is incorrect for machine.</li> <li>4. Motor connection wired incorrectly.</li> <li>5. Motor overheated.</li> <li>6. Centrifugal switch at fault.</li> <li>7. Motor at fault.</li> </ol>	<ol style="list-style-type: none"> <li>1. Reduce pressure when feeding workpiece.</li> <li>2. Straighten workpiece or use a different one.</li> <li>3. Only sand wood and ensure moisture is below 20%.</li> <li>4. Review wiring diagram on motor cover; correct wire connections.</li> <li>5. Let cool, clean motor, and reduce workload.</li> <li>6. Adjust/replace centrifugal switch if available.</li> <li>7. Test, repair, or replace motor.</li> </ol>



# Troubleshooting

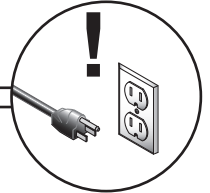

## Workpiece Finish

Symptom	Possible Cause	Possible Solution
Miter bar loose or binds in miter slot.	1. Miter slot dirty or gummed up.	1. Carefully clean miter slot.
Workpiece angle incorrect or out of square.	1. Pointer or scale not calibrated correctly.	1. Adjust pointer or scale to reflect real path of cut.
Sandpaper clogs quickly or burns.	<ol style="list-style-type: none"> <li>1. Sandpaper grit is too fine for the job.</li> <li>2. Workpiece is too moist.</li> <li>3. Sanding depth too aggressive.</li> <li>4. Paint, varnish, pitch, or other coating is loading up sandpaper.</li> <li>5. Sanding soft workpiece.</li> </ol>	<ol style="list-style-type: none"> <li>1. Replace with a coarser grit sandpaper.</li> <li>2. Allow workpiece to dry out.</li> <li>3. Reduce sanding depth or install coarser sandpaper.</li> <li>4. Install a coarse grit sandpaper, or strip coating off before sanding.</li> <li>5. Use different stock. Or, accept the characteristics of the stock and plan on cleaning/replacing discs frequently.</li> </ol>
Glossy spots, burning, or streaks on workpiece.	<ol style="list-style-type: none"> <li>1. Sandpaper too fine for the desired finish.</li> <li>2. Work held still for too long.</li> <li>3. Workpiece is too moist.</li> <li>4. Sanding stock with high residue.</li> <li>5. Worn sandpaper.</li> <li>6. Sanding depth too aggressive.</li> </ol>	<ol style="list-style-type: none"> <li>1. Use a coarser grit sandpaper.</li> <li>2. Do not keep workpiece in one place for too long.</li> <li>3. Allow workpiece to dry out.</li> <li>4. Use different stock. Or, accept the characteristics of the stock and plan on cleaning/replacing sandpapers frequently.</li> <li>5. Replace sandpaper.</li> <li>6. Reduce sanding depth or install coarser sandpaper.</li> </ol>
Abrasive rubs off the belt easily.	1. Sandpaper has been stored in an incorrect environment.	1. Store sandpaper away from extremely dry, hot, or damp conditions.



# Table/Disc Parallelism

The edge of the table must be parallel with the face of the sanding disc, and there should be a gap between the two. This gap should be large enough so that the sandpaper does not rub against the table, but small enough so that the gap is not a pinch hazard.

## To make the table and sanding disc parallel:

1. DISCONNECT MACHINE FROM POWER!
2. Using a 10mm wrench, loosen the six hex bolts that secure the table to the table support brackets.
3. Adjust the table so that there is a  $\frac{1}{16}$ " gap (**Figure 17**) between the 12" disc (with sandpaper installed) and the table.

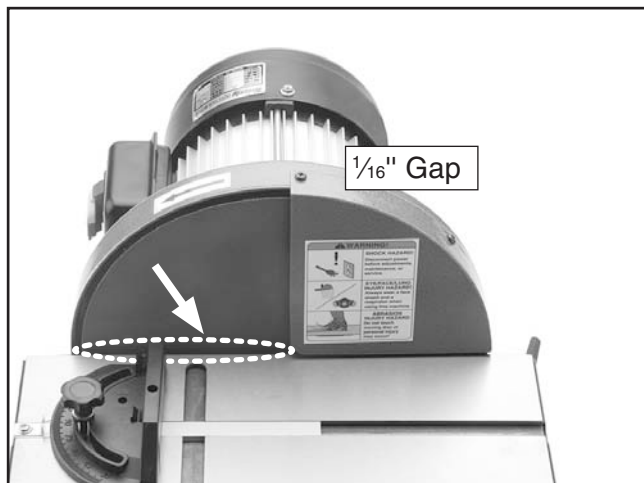

**Figure 17.** Table parallel with sanding disc.

4. When the table is parallel with the sanding disc, tighten the hex bolts.
  5. Spin the disc by hand to check if the sandpaper is touching the table.
- Note:** *DO NOT turn the disc sander on at this point.*
6. Re-adjust the table parallelism if the sandpaper touches the table at any point in its rotation.

# Miter Gauge Calibration

At 90° the miter gauge should be perpendicular to the face of the wheel when it is mounted in the table slot. If not follow this procedure.

## To calibrate the miter gauge:

1. DISCONNECT MACHINE FROM POWER!
2. Use a try square or machinist's square with one edge against the face of the miter gauge and the other against the disc face, as shown in **Figure 18**.



**Figure 18.** Squaring miter gauge to disc.

3. Loosen the lock knob on the miter gauge and adjust the face of the miter gauge so it is flush with the edge of the square, tighten the gauge lock knob, and verify the setting.
4. Using a Phillips head screwdriver, loosen the degree scale pointer, position the pointer on 90°, and retighten the screw.
5. Recheck the miter scale accuracy with the square.



# Table Tilt Calibration

When the table tilt is set to 90°, the table should be positioned perpendicular to the sanding disc face. If not follow this procedure.

## To calibrate the table tilt:

1. DISCONNECT MACHINE FROM POWER!
2. Using a try square or machinist's square, set one edge on the table surface and the other against the face of the disc, as shown in **Figure 19**.

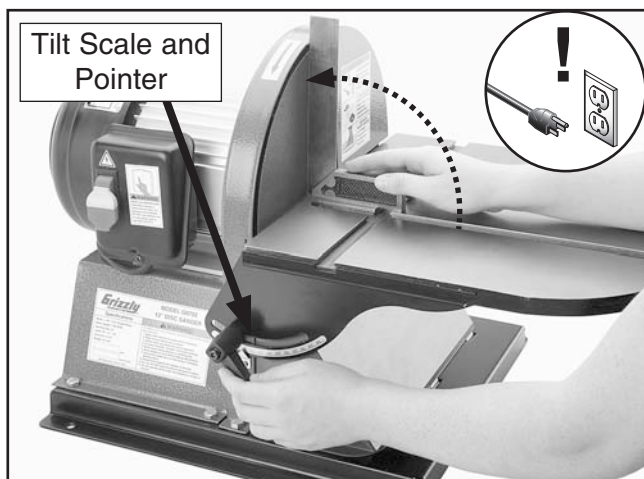

**Figure 19.** Squaring the table.

**Note:** This can be done with the sandpaper installed, although it is somewhat more precise if the sandpaper is not installed.

3. Loosen the lock levers and adjust the table angle until it is perfectly perpendicular to the disc, then tighten the lock levers while holding the table in place.
4. Using a Phillips head screwdriver, loosen the degree scale pointer, index the pointer on 0°, and retighten the screw.
5. Recheck the scale accuracy with the square.





# SECTION 8: WIRING

These pages are current at the time of printing. However, in the spirit of improvement, we may make changes to the electrical systems of future machines. Study this section carefully. If there are differences between your machine and what is shown in this section, call Technical Support at (570) 546-9663 for assistance BEFORE making any changes to the wiring on your machine.

## WARNING















### Wiring Safety Instructions

- SHOCK HAZARD.** Working on wiring that is connected to a power source is extremely dangerous. Touching electrified parts will result in personal injury including but not limited to severe burns, electrocution, or death. Disconnect the power from the machine before servicing electrical components!
- MODIFICATIONS.** Modifying the wiring beyond what is shown in the diagram may lead to unpredictable results, including serious injury or fire. This includes the installation of unapproved aftermarket parts.
- WIRE CONNECTIONS.** All connections must be tight to prevent wires from loosening during machine operation. Double-check all wires disconnected or connected during any wiring task to ensure tight connections.
- CIRCUIT REQUIREMENTS.** You MUST follow the requirements at the beginning of this manual when connecting your machine to a power source.
- WIRE/COMPONENT DAMAGE.** Damaged wires or components increase the risk of serious personal injury, fire, or machine damage. If you notice that any wires or components are damaged while performing a wiring task, replace those wires or components.
- MOTOR WIRING.** The motor wiring shown in these diagrams is current at the time of printing but may not match your machine. If you find this to be the case, use the wiring diagram inside the motor junction box.
- CAPACITORS/INVERTERS.** Some capacitors and power inverters store an electrical charge for up to 10 minutes after being disconnected from the power source. To reduce the risk of being shocked, wait at least this long before working on capacitors.
- EXPERIENCING DIFFICULTIES.** If you are experiencing difficulties understanding the information included in this section, contact our Technical Support at (570) 546-9663.

#### NOTICE

The photos and diagrams included in this section are best viewed in color. You can view these pages in color at [www.grizzly.com](http://www.grizzly.com).

#### COLOR KEY

BLACK 	BLUE 	YELLOW 	LIGHT BLUE 
WHITE 	BROWN 	YELLOW GREEN 	BLUE WHITE 
GREEN 	GRAY 	PURPLE 	TURQUOISE 
RED 	ORANGE 	PINK 	



# Wiring Diagram



View this page in color at [www.grizzly.com](http://www.grizzly.com).



Figure 20. Electrical system.

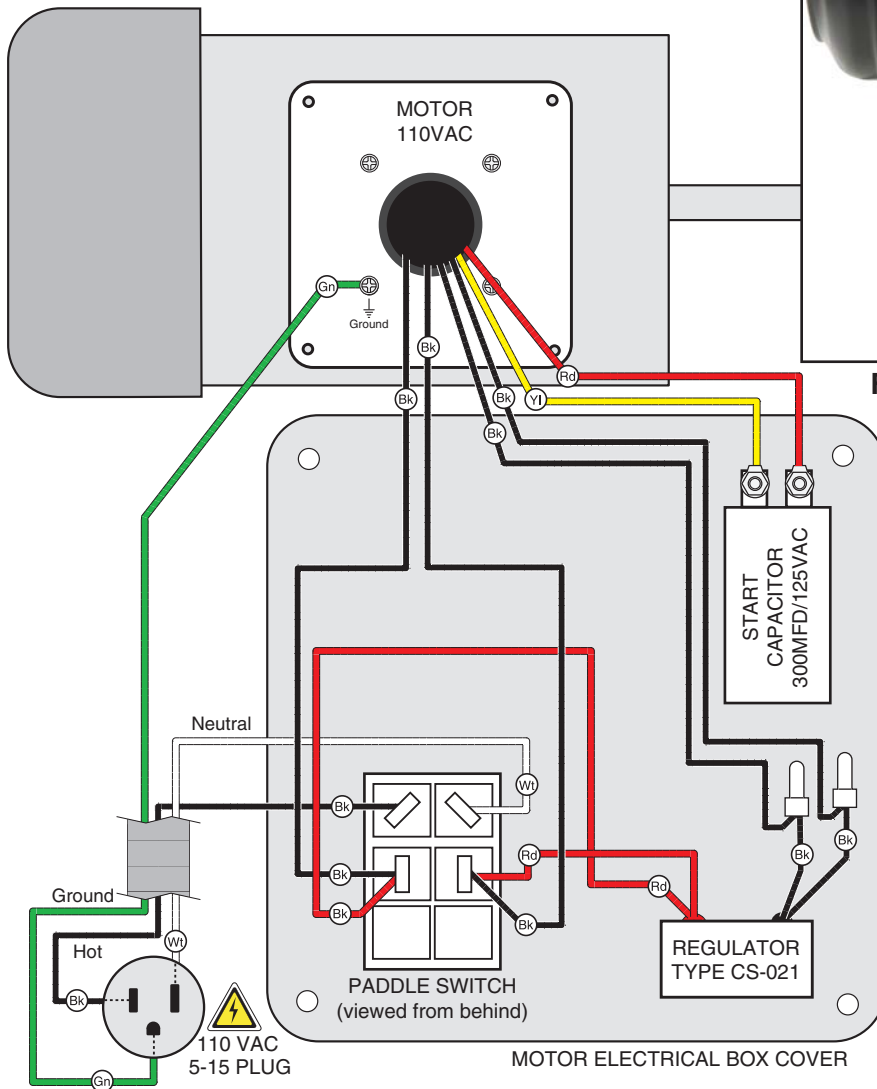

**NOTICE**  
The motor wiring shown here is current at the time of printing, but it may not match your machine. Always use the wiring diagram inside the motor junction box.



# SECTION 9: PARTS

## Main Breakdown and Parts List

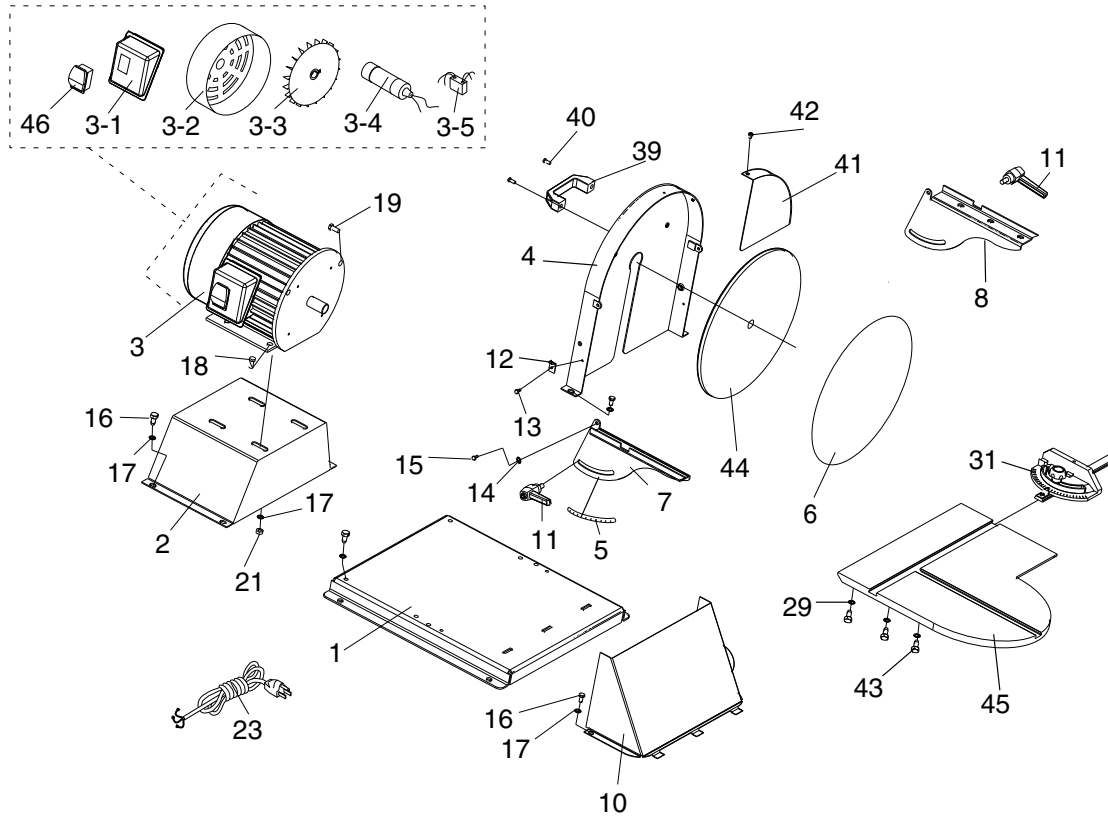

REF PART #	DESCRIPTION
1	P0702001 MACHINE BASE
2	P0702002 MOTOR BASE
3	P0702003 MOTOR 3/4HP 110V
3-1	P0702003-1 ELECTRICAL BOX COVER
3-2	P0702003-2 FAN COVER
3-3	P0702003-3 FAN
3-4	PC300B S. CAPACITOR 300M 125V 1-3/4 X 3-3/8
3-5	P0702003-5 REGULATOR TYPE CS-021
4	P0702004 DISC HOUSING
5	P0702005 ADHESIVE SCALE
6	P0702006 ADHESIVE 12" SANDING DISC 100 GRIT
7	P0702007 LEFT TRUNNION
8	P0702008 RIGHT TRUNNION
10	P0702010 DUST HOOD
11	P0702011 ADJUSTABLE HANDLE
12	P0702012 TRUNNION SCALE POINTER
13	PS07M PHLP HD SCR M4-.7 X 8
14	PLW03M LOCK WASHER 6MM
15	PS03M PHLP HD SCR M6-1 X 8
16	PS14M PHLP HD SCR M6-1 X 12

REF PART #	DESCRIPTION
17	PW03M FLAT WASHER 6MM
18	PS32M PHLP HD SCR M8-1.25 X 25
19	PS04M PHLP HD SCR M8-1.25 X 20
21	PN03M HEX NUT M8-1.25
23	PWRCRD110L POWER CORD 16AWG X 3C X 73"L
29	PW03M FLAT WASHER 6MM
31	P0702031 MITER GAUGE ASSEMBLY
39	P0702039 LIFTING HANDLE
40	PCAP02M CAP SCREW M6-1 X 20
41	P0702041 SAFETY GUARD
42	PS05M PHLP HD SCR M5-.8 X 8
43	PB02M HEX BOLT M6-1 X 12
44	P0702044 CAST IRON DISC
45	P0702045 TABLE
46	G8988 SWITCH
100	PLABEL-12C READ MANUAL LABEL
101	P0702101 ARROW LABEL
102	P0702102 GUARD WARNING LABEL
103	P0702103 COMBO WARNING LABEL
104	P0702104 MACHINE ID LABEL



# Label Parts List

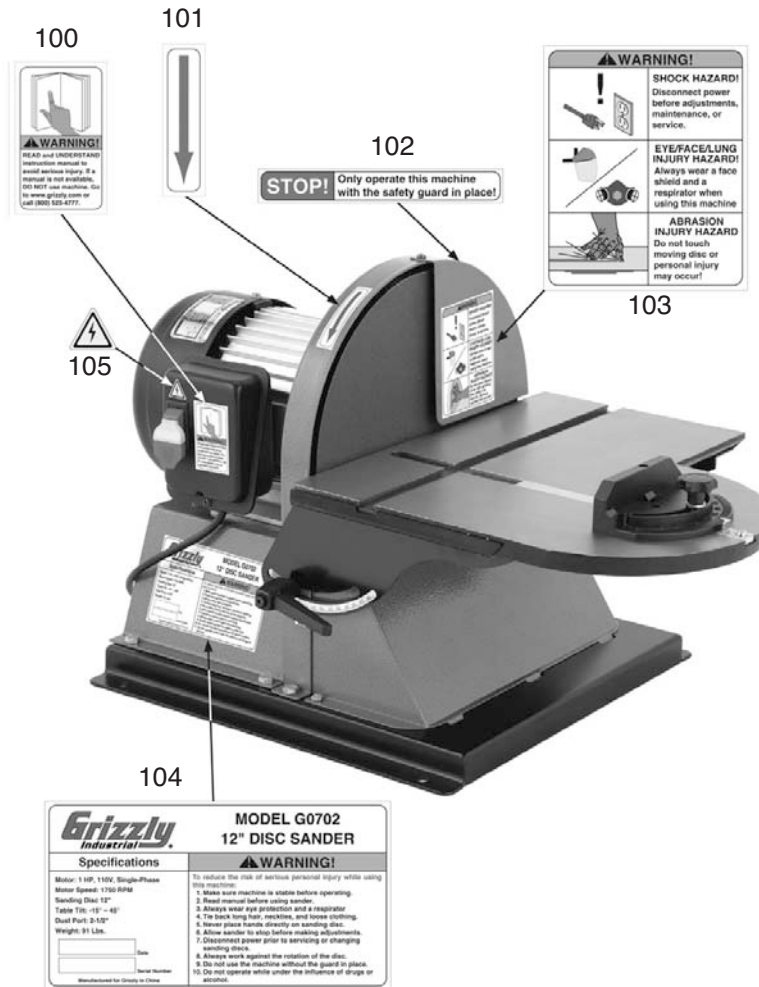

REF	PART #	DESCRIPTION
100	PLABEL-12C	READ MANUAL LABEL
101	P0702101	ARROW LABEL
102	P0702102	GUARD WARNING LABEL

REF	PART #	DESCRIPTION
103	P0702103	COMBO WARNING LABEL
104	P0702104	MACHINE ID LABEL
105	PLABEL-14B	ELECTRICITY LABEL

## WARNING

Safety labels warn about machine hazards and ways to prevent injury. The owner of this machine **MUST** maintain the original location and readability of the labels on the machine. If any label is removed or becomes unreadable, **REPLACE** that label before using the machine again. Contact Grizzly at (800) 523-4777 or [www.grizzly.com](http://www.grizzly.com) to order new labels.





# WARRANTY CARD

Name \_\_\_\_\_

Street \_\_\_\_\_

City \_\_\_\_\_ State \_\_\_\_\_ Zip \_\_\_\_\_

Phone # \_\_\_\_\_ Email \_\_\_\_\_ Invoice # \_\_\_\_\_

Model # \_\_\_\_\_ Order # \_\_\_\_\_ Serial # \_\_\_\_\_

The following information is given on a voluntary basis. It will be used for marketing purposes to help us develop better products and services. **Of course, all information is strictly confidential.**

1. How did you learn about us?

- Advertisement
- Card Deck
- Friend
- Website
- Catalog
- Other:

2. Which of the following magazines do you subscribe to?

- |   |  |   |
|---|--|---|
| <input type="checkbox"/> Cabinet Maker          | <input type="checkbox"/> Popular Mechanics   | <input type="checkbox"/> Today's Homeowner    |
| <input type="checkbox"/> Family Handyman        | <input type="checkbox"/> Popular Science     | <input type="checkbox"/> Wood                 |
| <input type="checkbox"/> Hand Loader            | <input type="checkbox"/> Popular Woodworking | <input type="checkbox"/> Wooden Boat          |
| <input type="checkbox"/> Handy                  | <input type="checkbox"/> Practical Homeowner | <input type="checkbox"/> Woodshop News        |
| <input type="checkbox"/> Home Shop Machinist    | <input type="checkbox"/> Precision Shooter   | <input type="checkbox"/> Woodsmith            |
| <input type="checkbox"/> Journal of Light Cont. | <input type="checkbox"/> Projects in Metal   | <input type="checkbox"/> Woodwork             |
| <input type="checkbox"/> Live Steam             | <input type="checkbox"/> RC Modeler          | <input type="checkbox"/> Woodworker West      |
| <input type="checkbox"/> Model Airplane News    | <input type="checkbox"/> Rifle               | <input type="checkbox"/> Woodworker's Journal |
| <input type="checkbox"/> Modeltec               | <input type="checkbox"/> Shop Notes          | <input type="checkbox"/> Other:               |
| <input type="checkbox"/> Old House Journal      | <input type="checkbox"/> Shotgun News        |   |

3. What is your annual household income?

- \$20,000-\$29,000
- \$30,000-\$39,000
- \$40,000-\$49,000
- \$50,000-\$59,000
- \$60,000-\$69,000
- \$70,000+

4. What is your age group?

- 20-29
- 30-39
- 40-49
- 50-59
- 60-69
- 70+

5. How long have you been a woodworker/metalworker?

- 0-2 Years
- 2-8 Years
- 8-20 Years
- 20+ Years

6. How many of your machines or tools are Grizzly?

- 0-2
- 3-5
- 6-9
- 10+

7. Do you think your machine represents a good value?  Yes  No

8. Would you recommend Grizzly Industrial to a friend?  Yes  No

9. Would you allow us to use your name as a reference for Grizzly customers in your area?  
**Note: We never use names more than 3 times.**  Yes  No

10. Comments: \_\_\_\_\_

---



---



---

CUT ALONG DOTTED LINE

FOLD ALONG DOTTED LINE

\_\_\_\_\_
\_\_\_\_\_
\_\_\_\_\_



Place Stamp Here



GRIZZLY INDUSTRIAL, INC.
P.O. BOX 2069
BELLINGHAM, WA 98227-2069



FOLD ALONG DOTTED LINE

Send a Grizzly Catalog to a friend:

Name \_\_\_\_\_
Street \_\_\_\_\_
City \_\_\_\_\_ State \_\_\_\_\_ Zip \_\_\_\_\_

TAPE ALONG EDGES--PLEASE DO NOT STAPLE

# WARRANTY AND RETURNS

---

Grizzly Industrial, Inc. warrants every product it sells for a period of **1 year** to the original purchaser from the date of purchase. This warranty does not apply to defects due directly or indirectly to misuse, abuse, negligence, accidents, repairs or alterations or lack of maintenance. This is Grizzly's sole written warranty and any and all warranties that may be implied by law, including any merchantability or fitness, for any particular purpose, are hereby limited to the duration of this written warranty. We do not warrant or represent that the merchandise complies with the provisions of any law or acts unless the manufacturer so warrants. In no event shall Grizzly's liability under this warranty exceed the purchase price paid for the product and any legal actions brought against Grizzly shall be tried in the State of Washington, County of Whatcom.

We shall in no event be liable for death, injuries to persons or property or for incidental, contingent, special, or consequential damages arising from the use of our products.

To take advantage of this warranty, contact us by mail or phone and give us all the details. We will then issue you a "Return Number," which must be clearly posted on the outside as well as the inside of the carton. We will not accept any item back without this number. Proof of purchase must accompany the merchandise.

The manufacturers reserve the right to change specifications at any time because they constantly strive to achieve better quality equipment. We make every effort to ensure that our products meet high quality and durability standards and we hope you never need to use this warranty.

Please feel free to write or call us if you have any questions about the machine or the manual.

Thank you again for your business and continued support. We hope to serve you again soon.

# *grizzly.com*<sup>®</sup>

**TOOL WEBSITE**

Buy Direct and Save with Grizzly<sup>®</sup> – Trusted, Proven and a Great Value!  
~Since 1983~

*Visit Our Website Today For  
Current Specials!*

**ORDER  
24 HOURS A DAY!  
1-800-523-4777**

